

HOLES. A. 5.1 X 6 DEEP 6 OFF.  
 MATERIAL 30 DIA. STEEL 230M07  
 QUANTITY 1 OFF  
HEAD 4

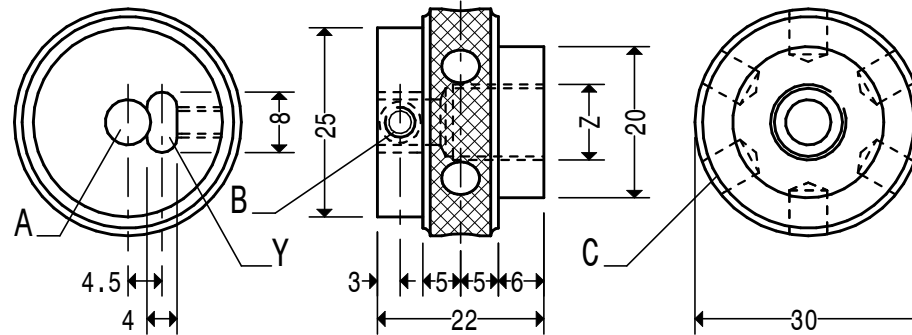

HOLES. A. 6 B. M4 C. 5.1 X 6 DEEP 6 OFF.  
 Z. 3/8" X 32 TPI ME THREAD X 12 DEEP  
 Y. MAKE RECESS 6 DEEP MATERIAL 30 DIA. STEEL 230M07  
SECURING NUT 3

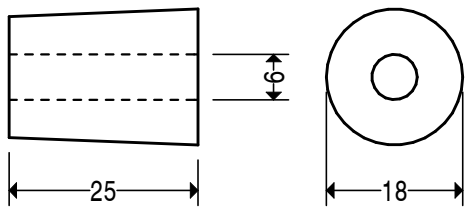

MATERIAL 20 DIA. STEEL 230M07  
 TAPER, AS NUMBER TWO MORSE  
 QUANTITY 1 OFF  
STOP BAR SUPPORT 7

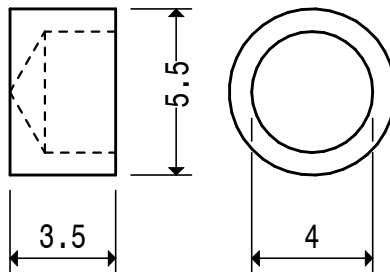

MATERIAL  
 6 DIA. STEEL 230M07  
 QUANTITY 2 OFF  
CLAMP PAD 1

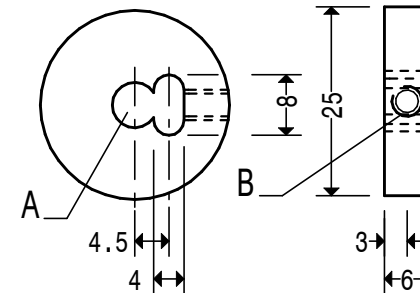

HOLES. A. 6 B. M4  
 MATERIAL 25 DIA. STEEL 230M07  
 QUANTITY 1 OFF  
SETTING PIECE 2

